

**MGEH Grooving Tools (Depth < 20mm)**

MGEH 外徑切槽刀 (切深 < 20mm)

**External Tool Holder Specifications 外徑刀桿規格**

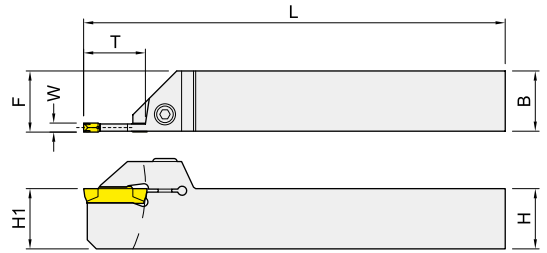
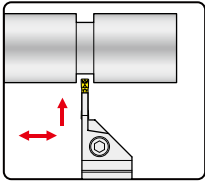

Right-hand shown

Insert Brand : Winstar, Korloy, ...

Order No.	Dimensions (mm)						Inserts	Screw	Wrench
	H (H1)	B	L	F	T	W			
IMGEH <sup>R</sup> / <sub>L</sub> 1616K2T16T	16	16	125	16.25	16	2.0	MGMN200.. MRMN200..	IHTMT520	IETL25
IMGEH <sup>R</sup> / <sub>L</sub> 2020K2T20T	20	20	125	20.25	20	2.0		IHTMT525	IETL25
IMGEH <sup>R</sup> / <sub>L</sub> 2525M2T20T	25	25	150	25.25	20	2.0		IHTMT525	IETL25
IMGEH <sup>R</sup> / <sub>L</sub> 1616K3T20T	16	16	125	16.30	20	3.0	MGMN300.. MRMG300..	IHTMT520	IETL25
IMGEH <sup>R</sup> / <sub>L</sub> 2020K3T20T	20	20	125	20.30	20	3.0		IHTMT525	IETL25
IMGEHR2525M3T20T	25	25	150	25.30	20	3.0		IHTMT525	IETL25
IMGEHR2525M4T20T	25	25	150	25.35	20	4.0	MGMN400.. MRMN400..	IHTMT525	IETL25

**MGIV Grooving Tools (Depth < 15mm)** MGIV 內徑切槽刀 (切深 < 15mm)

**Internal Tool Holder Specifications** 內徑刀桿規格

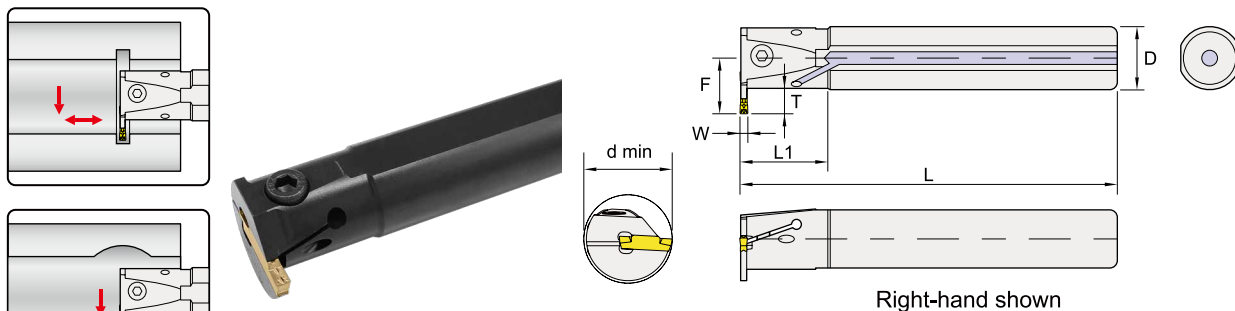

Insert Brand : Winstar, Korloy, ...

Order No.	Dimensions (mm)							Insert	Screw	Wrench
	D	L	L1	F	T	W	d min			
IMGIVR2016M2	16	150	25	12	4	2	20	MGMN200.. MRMN200..	ICSH0310	IPL25
IMGIVR2520M2	20	150	25	14.5	4	2	25		ICSH0512	IPL40
IMGIVR2925R2	25	200	30	16	4	2	29		ICSH0516	IPL40
IMGIVR2620M3	20	150	25	16.5	6	3	26	MGMN300.. MRMG300..	ICSH0512	IPL40
IMGIVR3020M3	20	150	25	20	10	3	30		ICSH0512	IPL40
IMGIVR3125R3	25	200	30	18	6	3	31		ICSH0516	IPL40
IMGIVR3525R3	25	200	30	22	10	3	35		ICSH0516	IPL40
IMGIVR3832S3	32	250	40	21.5	6	3	38		ICSH0516	IPL40
IMGIVR4232S3	32	250	40	25.5	10	3	42		ICSH0516	IPL40
IMGIVR2620M4	20	150	25	15.5	6	4	26		MGMN400.. MRMN400..	ICSH0512
IMGIVR3020M4	20	150	25	20	10	4	30	ICSH0512		IPL40
IMGIVR3125R4	25	200	30	18.5	6	4	31	ICSH0516		IPL40
IMGIVR3525R4	25	200	30	22.5	10	4	35	ICSH0516		IPL40
IMGIVR3832S4	32	250	40	22	6	4	38	ICSH0516		IPL40
IMGIVR4232S4	32	250	40	26	10	4	42	ICSH0516		IPL40
IMGIVR5040T4	40	300	45	29.5	10	4	50	ICSH0516		IPL40
IMGIVR5540T4	40	300	45	34.5	15	4	55	ICSH0516		IPL40

Recommended Cutting Conditions 建議切削數據

Working Material	Vc (m/min)	Parting off, fr (mm/rev)			Grooving, fr (mm/rev)		
		Cutting Width (w)					
		2	3	4	2	3	4
Carbon Steel / Alloy Steel	80 ~ 200	0.02 ~ 0.14	0.03 ~ 0.21	0.04 ~ 0.28	0.04 ~ 0.08	0.06 ~ 0.12	0.08 ~ 0.16
Stainless Steel	60 ~ 140	0.02 ~ 0.10	0.03 ~ 0.15	0.04 ~ 0.20	0.04 ~ 0.06	0.06 ~ 0.09	0.08 ~ 0.12
Cast Iron	80 ~ 200	0.04 ~ 0.14	0.06 ~ 0.21	0.08 ~ 0.28	0.04 ~ 0.08	0.06 ~ 0.12	0.08 ~ 0.16
High Temperature Alloy	50 ~ 100	0.02 ~ 0.06	0.03 ~ 0.09	0.04 ~ 0.12	0.02 ~ 0.04	0.03 ~ 0.06	0.04 ~ 0.08

Insert Specifications 刀片規格

Insert	Dimensions (mm)					Chipbreaker 斷屑槽	
	w	r	l	h	m	SG	MG
MGMN200	2.0	0.2	16	3.5	1.60	SG	For light cutting 適合輕加工
MGMN300	3.0	0.4	21	4.8	2.35	MG	For general cutting 適合一般泛用加工
MGMN400	4.0	0.4	21	4.8	3.30		
MRMN200	2.0	1.0	16	3.5	1.60		
MRMN300	3.0	1.5	21	4.8	2.35		
MRMN400	4.0	2.0	21	4.8	3.30		

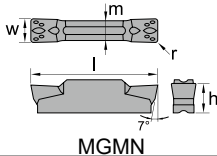
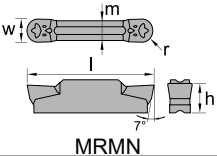
Insert Designation 刀片型號

Insert	Order No.	Code-Chipbreaker-Grade	Working Material					
			P	M	K	N	S	H
	IMGMN200SG33TX	MGMN200-SG-CX33TX	●	●	●		●	●
	IMGMN200SG43TX	MGMN200-SG-CX43TX	●	●	●		○	
	IMGMN300MG33TX	MGMN300-MG-CX33TX	●	●	●		●	●
	IMGMN300MG43TX	MGMN300-MG-CX43TX	●	●	●		○	
	IMGMN400MG33TX	MGMN400-MG-CX33TX	●	●	●		●	●
	IMGMN400MG43TX	MGMN400-MG-CX43TX	●	●	●		○	
	IMRMN200MG33TX	MRMN200-MG-CX33TX	●	●	●		●	●
	IMRMN200MG43TX	MRMN200-MG-CX43TX	●	●	●		○	
	IMRMN300MG33TX	MRMN300-MG-CX33TX	●	●	●		●	●
	IMRMN300MG43TX	MRMN300-MG-CX43TX	●	●	●		○	
	IMRMN400MG33TX	MRMN400-MG-CX33TX	●	●	●		●	●
	IMRMN400MG43TX	MRMN400-MG-CX43TX	●	●	●		○	

\* CX33TX for General cutting.  
CX43TX for Interrupted cutting.